

**CURTISS -
WRIGHT**



Valves Division

2400 SERIES

Pressure Relief Valve Product Catalog



Table of Contents

- 4** Services
- 5** Product Overview
- 6** Valve Diagram
- 7** Materials of Construction
- 8** Model Number System and Connection Types
- 9** Seat Materials and Set Pressures
- 10** Capacity Tables
- 11** Packed Lifting Lever
- 12** Threaded Dimensions and Weights
- 13** Flanged Dimensions and Weights
- 14** Portfolio of Pressure Relief Valves
- 15** Certifications and Approvals
- 16** Warranty





Our Commitment

We provide customers with total pressure relief management solutions transforming the way you ensure plant safety. We are a global company with local presence.

Our Company

Since 1943 **Farris Engineering**, part of the Valves Division of Curtiss-Wright, is at the forefront in the design and manufacturing of spring-loaded and pilot-operated pressure relief valves. With over 75 years of proven performance, Farris Engineering is committed to providing high quality products and services so our customers can increase productivity and minimize downtime.

Curtiss-Wright provides highly engineered products and services with a focus on advanced technologies for high performance platforms and critical applications. Our technological expertise spans decades of innovation and we have compiled an extensive portfolio of critical technologies serving commercial, defense, energy and industrial markets. Our technologies, some that are sole source or first-of-a-kind, achieve the demanding performance levels required for optimal safety, performance and reliability in difficult “must not fail” applications.

Services

Farris Engineering is Available to Help You.

We provide a spectrum of services including product sizing, selection, system design and audit services.



Product Sizing & Selection

For optimal system performance it is critical to determine the correct product for your application. Our sizing selection software, **SizeMaster™**, assists with the task of deciding the right relief valve for your application.

You can access the software by visiting www.sizemaster.com or contacting your local representative.

Relief System Design

For pressure relief system design and audit services turn to **Farris Engineering Services (FES)**. Our team of experienced engineers offer complete relief system design and audit services using a patented, web-based software package, **iPRSM™**, which provides a comprehensive approach to the management of pressure relief systems for safety compliance. Contact your local representative for more information.

Local Support

Factory trained sales representatives are available to understand and meet your needs. Find your nearby service and support at www.cw-valvegroup.com/farrisdistributors

How to Order

All orders can be placed with your local Farris Engineering representative.

Our technical experts can assist with:

- Compliance with codes and standards
- Identifying the right valve for the application
- Determining valve size

Visit www.cw-valvegroup.com/farrisdistributors to find your local representative.

Aftermarket Services

Our network of certified valve technicians can provide quick maintenance and repair through our local **Farris Authorized Service Team (FAST)**. Contact your local FAST Center for valve repair and maintenance.

Factory Maintenance Certification Training is available for valve repair technicians. Contact the Farris Engineering Technical Trainer at techtrainer@curtisswright.com.

2400 Series Pressure Relief Valve Overview

A high performance direct spring loaded pressure relief valve with a soft seat design to provide reliable overpressure protection.



Target Markets & Applications

- Oil & Gas
- Chemical & Petrochemical
- Air Separation / Industrial Gas
- Cryogenic Service

Features & Benefits



Suitable for a wide range of service fluids and operating temperatures involving gas and vapor relief.



External blowdown control allows accurate blowdown adjustment without affecting set pressure.



The packed lifting lever is an optional accessory used to manually open the valve to test valve functionality.



Bubble tight seat design allows for processes to operate closer to set pressure minimizing leakage and frequent maintenance.



Full lift at set pressure reduces the potential for freeze-up in cryogenic applications.



Recommended spare parts are available as a kit, which allows for ease of ordering and reducing inventory items.



Soft seat design to minimize fugitive emissions and costly product loss.



Back pressure assists the spring to close the valve after relief cycle.



Certifications:
ASME Section VIII
CRN
PED

Valve Diagram

Plastic Seat Design

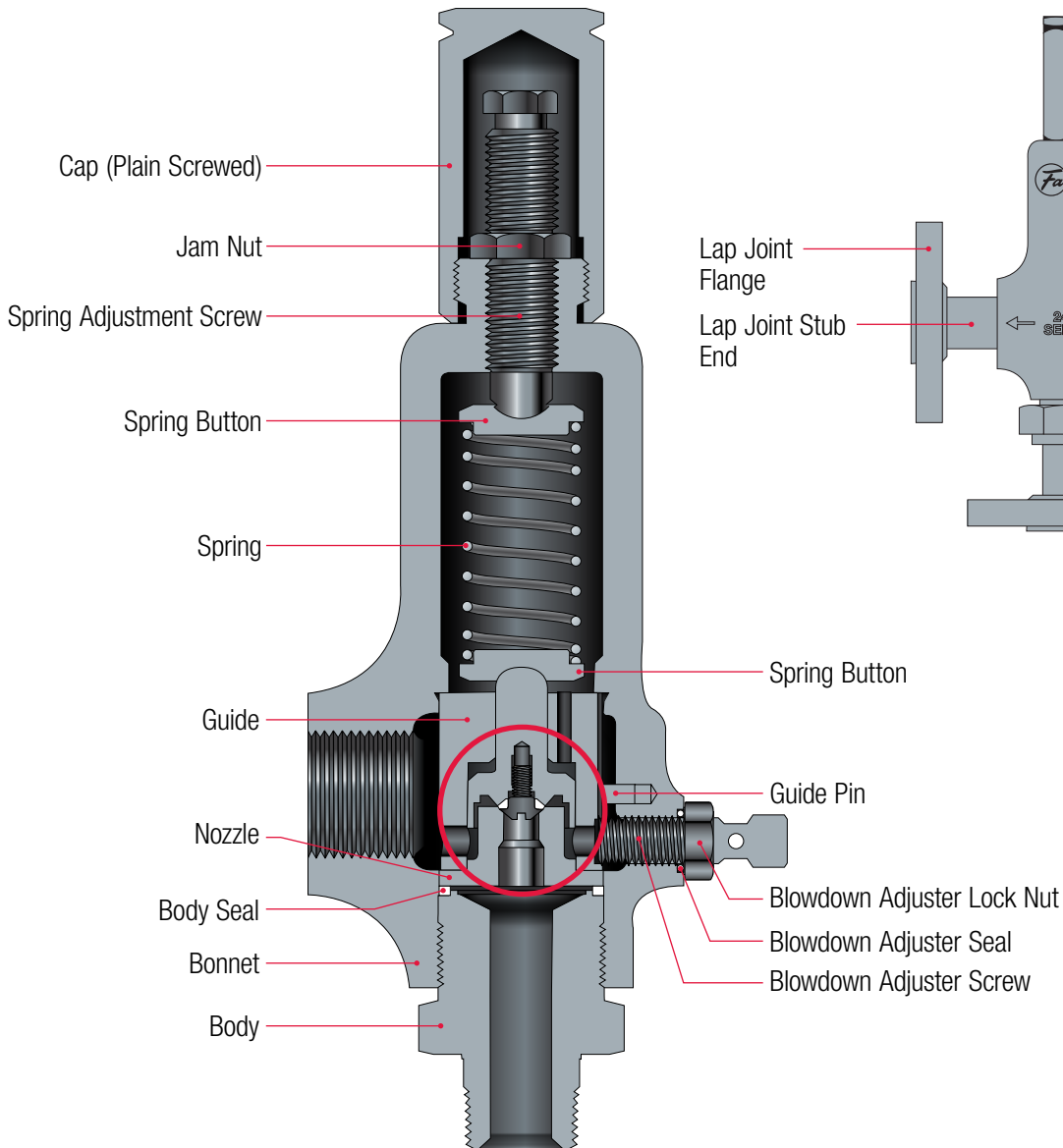

Flanged Design

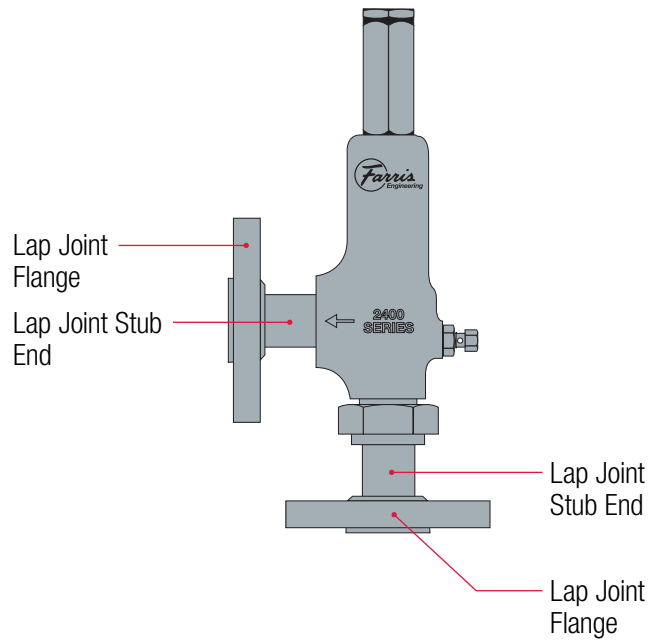

Plastic Seat

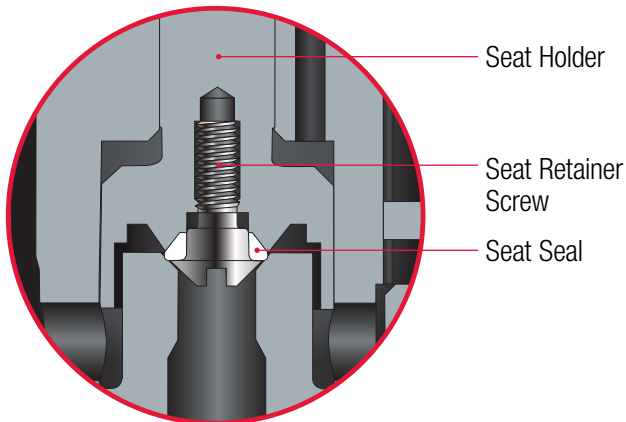

Elastomer Seat

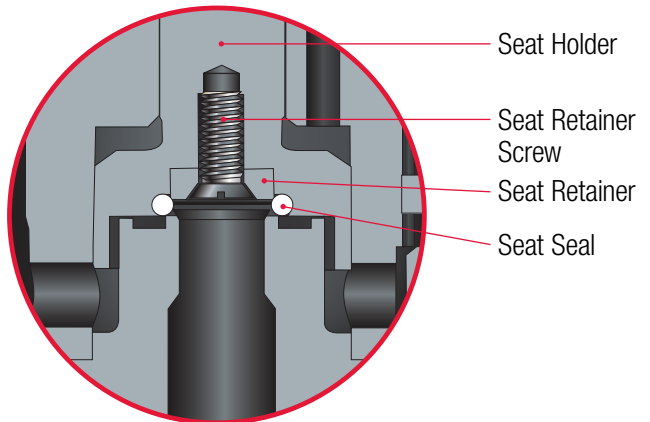

Materials of Construction

Part Name	Standard Carbon Steel (C1)	316 SS (S4)	Brass/Bronze (B4)
Body	316 SS ASME SA-479	316 SS ASME SA-479	Brass ASTM B16 H. H.
Bonnet	Carbon Steel ASME SA-216 Grade WCB	Stainless Steel ASME SA-351 Grade CF8M	Bronze ASME SB 62
Nozzle	316SS ASME SA-479	316SS ASME SA-479	Brass ASTM B16 H.H.
Guide	316 SS	316 SS	Brass ¹
Seat Holder			
Seat Retainer			
Seat Retainer Screw			
Seat Seal, Elastomer ²	See page 9		
Seat Seal, Plastic ²			
Spring Adjustment Screw	316 SS	316 SS	Brass
Jam Nut			
Guide Pin			316 SS
Blowdown Adjuster Screw			Brass
Lock Nut, Blowdown Adjustment			Brass
Cap, Plain Screwed	Carbon Steel	316 SS	Brass
Body Seal, Elastomer Seat ²	Same as selected seat materials		
Body Seal, Plastic Seat ²	Glass filled PTFE		
Blowdown Adjuster Seal	PTFE	PTFE	PTFE
Spring	Stainless Steel	316 SS	Stainless Steel
Spring Buttons	316 SS	316 SS	Brass
Wire Seal (Not Shown)	SS Wire / Lead Seal		
Nameplate (Not Shown)	Stainless Steel		
Lap Joint Stub End (Inlet)	316 SS	316 SS	N/A
Lap Joint Stub End (Outlet)			
Lap Joint Flange (Inlet)	Carbon Steel		
Lap Joint Flange (Outlet)	Carbon Steel		

Notes:

1. Plastic seated valves have a 316 SS seat retainer screw.
2. Recommended spare parts.

Materials of Construction NACE Compliance

Part Name	Standard Carbon Steel (N1)	316 SS (N4)
Body	316 SS (NACE)	316 SS (NACE)
Bonnet	Carbon Steel (NACE)	Stainless Steel (NACE)
Nozzle	316 SS (NACE)	316 SS (NACE)
Seat Holder		
Seat Retainer	Inconel X-750	Inconel X-750
Spring		
Lap Joint Stub End (Inlet)	316 SS (NACE)	316 SS (NACE)
Lap Joint Stub End (Outlet)	Carbon Steel (NACE)	316 SS (NACE)
Lap Joint Flange (Inlet)	Carbon Steel (NACE)	316 SS (NACE)
Lap Joint Flange (Outlet)	Carbon Steel (NACE)	316 SS (NACE)

Model Number System

Whether you are specifying a new, replacing an old or identifying an existing valve, our model number system will help.

Series Number – 2400 Series.

Orifice Letter – Letter is based on orifice area, generated after sizing calculation is performed using SizeMaster* to ensure proper fit. *SizeMaster is our web-based sizing selection software. www.sizemaster.com

Seat Material – Elastomer or Plastic. To determine appropriate seat material you must consider the system media, pressure and temperature ranges. Tables are provided on page 9 to assist with selection.

Inlet and Outlet Size and Connection Type – Based on compatibility with system piping.

Service Fluid – The type and state of fluid to be relieved.

Materials of Construction – Select to assure compatibility with process conditions.

Cap Type – Selection of a plain or packed lever cap should be based on code requirements and process conditions.

Accessory – Test gag option is available to hold valve closed when the system is being hydrostatically tested. Test gag requires packed lever cap.

The valve model number consists of designators in the sequence shown below.

24	B		V	2	M	3	F	G	-	C1	2	0
Series Number	Orifice Letter	Orifice Area		Seat Material ¹	Inlet		Outlet		Service Fluid	Body Material ¹	Cap Type	Accessory
		Square Inches	Square Millimeters		Size	Connection type	Size	Connection Type				
24	B	0.049	31.61	V FKM	1 1/2"	M Male NPT	2 3/4"	F Female NPT	G Gas/Vapor	C1 Stainless Body, Carbon Steel Bonnet S4 Complete 316 SS B4 ² Brass/Bronze N1 NACE, C1 Trim N4 NACE, S4 Trim	2 Plain 4 Packed Lever	0 No Gag 1 Test Gag
	D	0.110	70.97	B Buna N	2 3/4"	F Female NPT	3 1"	1 Flange 150 RF				
	E	0.196	126.45	E EPDM	3 1"	1 Flange 150 RF	2 Flange 300 RF	2 Flange 300 RF				
				K Kalrez® T PTFE L PCTFE	3 Flange 600 RF 4 Flange 900/1500 RF							

1. For other materials, contact your representative. www.cw-valvegroup.com/farrisdistributors

2. Brass/Bronze not available with flange connection.

Inlet and Outlet Combinations of Sizes and Connection Types

Valve Size Inlet x Outlet	Inlet Connection						Outlet Connection		
	NPT		Flange Class RF				NPT	Flange Class RF	
	Female	Male	150#	300#	600#	900/1500#	Female	150#	300#
B Orifice									
1/2" x 3/4"	✓	✓	✓	✓	✓	✓	✓		
1/2" x 1"	✓	✓	✓	✓	✓	✓	✓	✓	✓
3/4" x 1"	✓	✓	✓	✓	✓	✓	✓	✓	✓
1" x 1"		✓	✓	✓	✓	✓	✓	✓	✓
D Orifice									
1/2" x 1"	✓	✓	✓	✓	✓		✓	✓	
3/4" x 1"	✓	✓	✓	✓	✓		✓	✓	
1" x 1"	✓	✓	✓	✓	✓		✓	✓	
E Orifice									
3/4" x 1"	✓	✓	✓	✓	✓		✓	✓	
1" x 1"	✓	✓	✓	✓	✓		✓	✓	

Seat Materials and Set Pressures

The 2400 Series is provided with either an elastomer or a plastic seat. Valves with both seat materials are tested to meet the requirements of American Petroleum Institute (API) Standard 527 and provide zero leakage up to 95% of set pressure.

Seat Tightness Capabilities

Set Pressures Range	Operating Press. Range
100 psig (6.9 barg) and higher	0% to 95% of Set
50 to 99 psig (3.4 to 6.8 barg)	0% to 90% of Set
Below 50 psig (3.4 barg)	5 psig (.34 barg) below Set

Elastomer seat – Minimizes fugitive emissions and product loss.

Plastic seat – Suitable in cryogenic temperatures or corrosive applications. Plastic seat material selection is set pressure dependent.

Elastomer and Plastic Seat Pressure Range

	Seat Material	Seat Code	Set Pressure Range						Max. Back Pressure psig [barg] at 100°F [37.8°C]
			B Orifice		D Orifice		E Orifice		
			psig	barg	psig	barg	psig	barg	
Elastomer	FKM	V	20 to 2000	1.38 to 137.9	20 to 1410	1.38 to 97.2	20 to 600	1.38 to 41.4	400 [27.6]
	Buna N	B							
	EPDM	E							
	Kalrez	K							
Plastic	PTFE	T	50 to 1000	3.45 to 68.95	50 to 900	3.45 to 62.05	50 to 600	3.45 to 41.4	
	PCTFE	L	1001 to 2000	69.0 to 137.9	901 to 1410	62.15 to 97.2	—	—	

Flanged Set Pressure

Flange Class	Max. Set Pressure psig [barg] at 100°F [37.8°C]						Max. Back Pressure psig [barg]	
	B Orifice		D Orifice		E Orifice		C1/N1	S4/N4
	C1/N1	S4/N4	C1/N1	S4/N4	C1/N1	S4/N4		
150 RF	285 [19.65]	275 [18.96]	285 [19.65]	275 [18.96]	285 [19.65]	275 [18.96]	285 [19.65]	275 [18.96]
300 RF	740 [51]	720 [49.64]	740 [51]	720 [49.64]	600 [41.36]	600 [41.36]	400 [27.57]	400 [27.57]
600 RF	1480 [102]	1440 [99.28]	1410 [97.21]	1410 [97.21]	600 [41.36]	600 [41.36]	-	-
900/1500 RF	2000 [137.9]	2000 [137.9]	-	-	-	-	-	-

Temperature Range

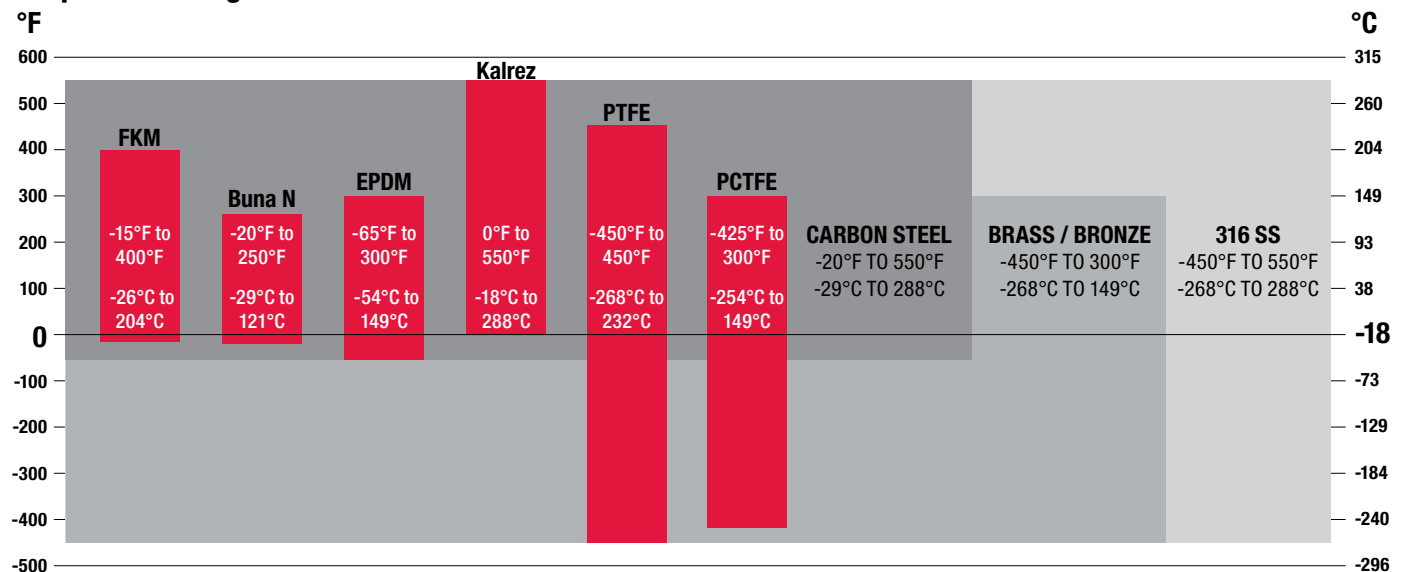

Note:

Temperature range may vary depending on service fluid and specific compound in a given material class. Contact manufacturer for carbon steel applications below -18°F.

Capacity Tables

Complies with ASME Pressure Vessel Code, Section VIII.
For sizing purposes the coefficient of discharge K_d is 0.817 for air, gas and vapor service.

AIR - 10% Overpressure Capacities in Standard Cubic Feet Per Minute at 60°F (Standard Cubic Meters Per Minute at 15.6°C)

Set Pressure (psig)	Orifice Area, Square Inches		
	B	D	E
	0.049	0.110	0.196
20 ¹	28	62	111
30 ¹	35	79	140
40	43	97	172
50	51	115	205
60	59	133	237
70	67	151	269
80	75	169	301
90	83	187	334
100	92	205	366
150	132	296	527
200	172	387	689
250	213	477	850
300	253	568	1012
350	293	658	1173
400	334	749	1335
450	374	840	1496
500	414	930	1658
550	455	1021	1819
600	495	1112	1981
650	535	1202	
700	576	1293	
750	616	1383	
800	657	1474	
850	697	1565	
900	737	1655	
950	778	1746	
1000	818	1836	
1050	858	1927	
1100	899	2018	
1150	939	2108	
1200	979	2199	
1250	1020	2289	
1300	1060	2380	
1350	1101	2471	
1400	1141	2561	
1450	1181		
1500	1222		
1550	1262		
1600	1302		
1650	1343		
1700	1383		
1750	1423		
1800	1464		
1850	1504		
1900	1545		
2000	1625		

Set Pressure (barg)	Orifice Area, Square Millimeters		
	B	D	E
	31.61	70.97	126.45
1.4 ²	0.8	1.9	3.2
2 ²	1.0	2.3	3.9
3	1.3	2.9	5.2
4	1.6	3.7	6.5
5	2.0	4.4	7.9
6	2.3	5.2	9.2
7	2.6	5.9	10.5
8	3.0	6.6	11.8
9	3.3	7.4	13.2
10	3.6	8.1	14.5
12	4.3	9.6	17.1
14	4.9	11.1	19.8
16	5.6	12.6	22.4
18	6.3	14.1	25.1
20	6.9	15.6	27.7
25	8.6	19.3	34.4
30	10.3	23.0	41.0
35	11.9	26.7	47.6
40	13.6	30.5	54.3
45	15.2	34.2	
50	16.9	37.9	
55	18.5	41.6	
60	20.2	45.3	
65	21.9	49.1	
70	23.5	52.8	
75	25.2	56.5	
80	26.8	60.2	
85	28.5	64.0	
90	30.1	67.7	
95	31.8	71.4	
100	33.5		
105	35.1		
110	36.8		
115	38.4		
120	40.1		
125	41.8		
130	43.4		
135	45.1		
138	46.1		

²Capacities at 2.0 barg and below are based on 0.2 bar overpressure.

¹Capacities at 30 psig and below are based on 3 psi overpressure.

Packed Lifting Lever

The packed lifting lever is for applications where periodic testing is desirable. The lifting lever allows the valve to be tested at operating pressures of at least 75% of the valve set pressure.

ASME Boiler and Pressure Vessel Code Section VIII requires a lifting device for pressure relief valves used on air, steam, and water (over 140°F / 60°C).

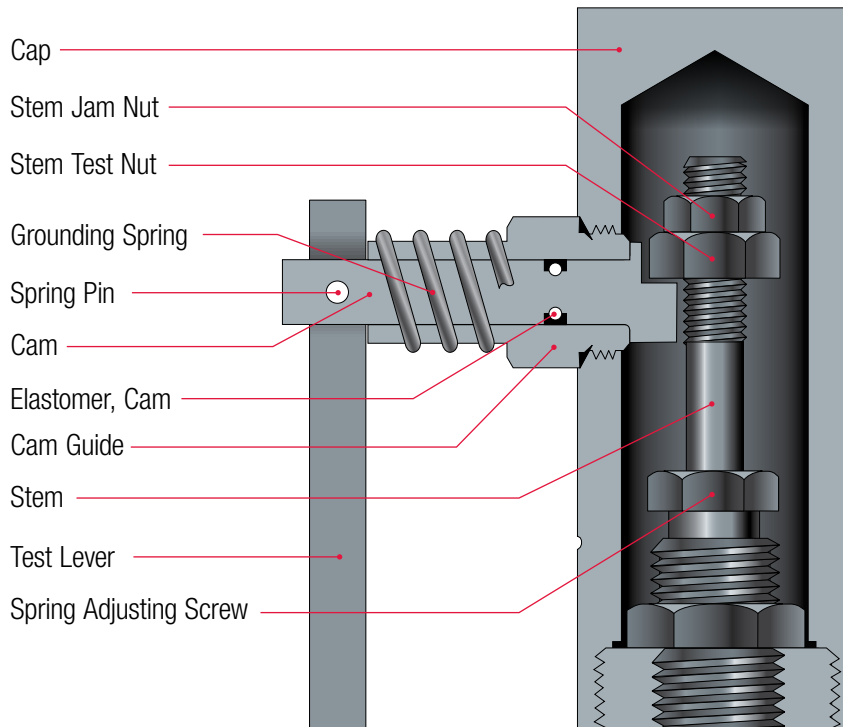

Cap Type	Part Name	Materials of Construction		
		Carbon Steel (C1)	316 SS (S4)	Brass/Bronze (B4)
Packed Lever	Cap, Packed	316 SS		316 SS
	Stem Jam Nut	Stainless Steel	316 SS	Stainless Steel
	Stem Test Nut			
	Grounding Spring		Stainless Steel	
	Spring Pin	Steel, Plated	Steel, Plated	Steel, Plated
	Cam	Stainless Steel	316 SS	Stainless Steel
	Elastomer, Cam	Same as selected seat material		
	Cam Guide	Stainless Steel	316 SS	Stainless Steel
	Stem			
	Test Lever			
	Spring Adjusting Screw		Stainless Steel	

Threaded Dimensions and Weights

Valve Size Inlet x Outlet	Connection Type	US Customary Units (inches)			Metric Units (millimeters)			Approx. Weight	
		A (Max.) Plain Cap ¹ Construction	B ²	C ²	A (Max.) Plain Cap Construction	B	C	Pounds	Kilograms
B Orifice									
1/2 x 3/4	MNPT x FNPT FNPT x FNPT	9 9/16	1 1/2	2 7/8	243	38	73	4 1/2	2.1
1/2 x 1	MNPT x FNPT FNPT x FNPT	9 9/16	1 1/2	2 7/8	243	38	73	4 1/2	2.1
3/4 x 3/4	MNPT x FNPT FNPT x FNPT	9 9/16 9 3/4	1 1/2	2 7/8 3 1/16	243 248	38	73 78	4 1/2	2.1
3/4 x 1	MNPT x FNPT FNPT x FNPT	9 9/16 9 3/4	1 1/2	2 7/8 3 1/16	243 248	38	73 78	4 1/2	2.1
1 x 1	MNPT x FNPT FNPT x FNPT	9 3/4	1 1/2	3 1/16	248	38	78	4 1/2	2.1
D Orifice									
1/2 x 1	MNPT x FNPT FNPT x FNPT	11	1 13/16	3 13/16 3 11/16	279	46	97 94	8 1/2	3.9
3/4 x 1	MNPT x FNPT FNPT x FNPT	11	1 13/16	3 13/16 3 11/16	279	46	97 94	8 1/2	3.9
1 x 1	MNPT x FNPT FNPT x FNPT	11	1 13/16	3 13/16 3 11/16	279	46	97 94	8 1/2	3.9
E Orifice									
3/4 x 1	MNPT x FNPT FNPT x FNPT	11	1 13/16	3 13/16 3 11/16	279	46	97 94	8 1/2	3.9
1 x 1	MNPT x FNPT FNPT x FNPT	11	1 13/16	3 13/16 3 11/16	279	46	97 94	8 1/2	3.9

Notes:

1. "A" dimensions shown are for plain cap valves, for packed lever cap, add 1".
2. Tolerance for "B" and "C" dimensions are $\pm 1/8"$.

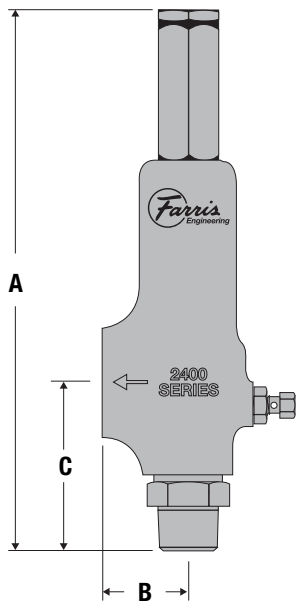

Threaded Connection

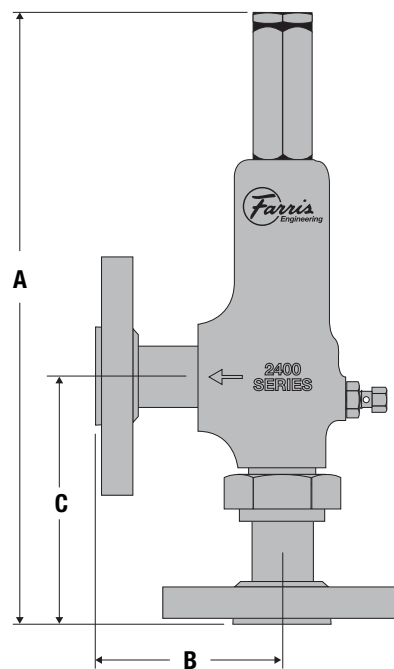

Flanged Connection



Flanged Dimensions and Weights

Valve Size	Connection Type Inlet RF	Connection Type Outlet RF	US Customary Units (inches)			Metric Units (millimeters)			Approx. Weight	
			A (Max.) Plain Cap ¹ Construction	B ²	C ²	A (Max.) Plain Cap Construction	B	C	Pounds	Kilograms
B Orifice										
1/2 x 1	150#	150#	12 1/8	4 3/4	4 13/16	308	121	22	8 1/2	3.9
	300#	150#	12 1/8	4 3/4	4 13/16	308	121	22	9	4.1
	600#	150#	12 1/4	4 3/4	5	311	121	127	9	4.1
	900#	300#	12 1/4	4 3/4	5	311	121	127	12 1/2	5.7
	1500#	300#	12 1/4	4 3/4	5	311	121	127	12 1/2	5.7
3/4 x 1	150#	150#	12	4 3/4	4 3/4	305	121	121	9	4.1
	300#	150#	12	4 3/4	4 3/4	305	121	121	10 1/2	4.8
	600#	150#	12	4 3/4	4 3/4	305	121	121	10 1/2	4.8
	900#	300#	12	4 3/4	5	305	121	127	14	6.4
	1500#	300#	12	4 3/4	5	305	121	127	14	6.4
1 x 1	150#	150#	12	4 3/4	4 3/4	305	121	121	10	4.5
	300#	150#	12	4 3/4	4 3/4	305	121	121	11	5
	600#	150#	12	4 3/4	4 3/4	305	121	121	11	5
	900#	300#	13	6 3/4	5 3/4	330	171	146	17 1/2	7.9
	1500#	300#	13	6 3/4	5 3/4	330	171	146	17 1/2	7.9
D Orifice										
1/2 x 1	150#	150#	12 1/8	4 3/4	4 13/16	308	121	122	11	5
	300#	150#	12 1/8	4 3/4	4 13/16	308	121	122	11 1/2	5.2
	600#	150#	12 1/4	4 3/4	5	311	121	127	11 1/2	5.2
3/4 x 1	150#	150#	12 1/16	4 3/4	4 3/4	306	121	121	11	5
	300#	150#	12 1/16	4 3/4	4 3/4	306	121	121	12 1/2	5.7
	600#	150#	12 1/16	4 3/4	4 3/4	306	121	121	12 1/2	5.7
1 x 1	150#	150#	12 1/16	4 3/4	4 3/4	306	121	121	12	5.4
	300#	150#	12 1/16	4 3/4	4 3/4	306	121	121	13	5.9
	600#	150#	12 1/16	4 3/4	4 3/4	306	121	121	13	5.9
E Orifice										
3/4 x 1	150#	150#	12 1/16	4 3/4	4 3/4	306	121	121	11 1/2	5.2
	300#	150#	12 1/16	4 3/4	4 3/4	306	121	121	12 1/2	5.7
	600#	150#	12 1/16	4 3/4	4 3/4	306	121	121	12 1/2	5.7
1 x 1	150#	150#	12 1/16	4 3/4	4 3/4	306	121	121	12	5.4
	300#	150#	12 1/16	4 3/4	4 3/4	306	121	121	13 1/2	6.1
	600#	150#	12 1/16	4 3/4	4 3/4	306	121	121	13 1/2	6.1

Notes:

1. "A" dimensions shown are for plain cap valves, for packed lever cap, add 1".
2. Tolerance for "B" and "C" dimensions are $\pm 1/8$ ".
3. Contact manufacturer for nonstandard dimensions

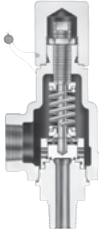
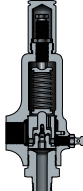
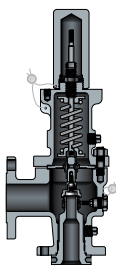
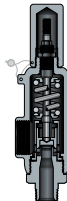
Portfolio of Pressure Relief Valves

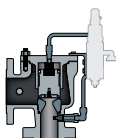
Valve	Material	Size Inches	Temperature Range	Pressure Range	ASME	Balanced or Bellows	Service				Nuclear	CE Stamped
							Air	Steam	Water	Multi		
 1890/1896M Series	Carbon Steel, Stainless Steel, Brass/Bronze	1/2" x 3/4" to 3/4" x 1"	-20°F to 750°F	15 psig to 800/300 psig	UV		✓	✓	✓			
 2400 Series	Carbon Steel, Stainless Steel and Brass/ Bronze	1/2" x 3/4" to 1" x 1"	-450°F to +550°F	20 psig to 2000 psig	UV		✓					✓
 2600 Series	Carbon Steel, Stainless Steel, Monel, Duplex & Hastelloy C	1" x 2" to 20" x 24"	-450°F to +1500°F	15 psig to 6170 psig	UV	✓	✓	✓			✓	✓
2600L Series					UV	✓	✓	✓	✓	✓	✓	✓
2600S Series					UV	✓	✓	✓				
 2700 Series	Carbon Steel, Stainless Steel, Monel & Hastelloy C	1/2" x 1" to 1-1/2" x 2-1/2"	-450°F to +750°F	15 psig to 6500 psig	UV	✓	✓	✓	✓	✓	✓	✓
 3700 Series	Carbon Steel, Stainless Steel	1/2" x 1" to 1-1/2" x 2-1/2"	-450°F to +750°F	15 psig to 6500 psig	UV		✓	✓	✓	✓		
 3800 Series Modulating Pilot	Carbon Steel, Stainless Steel, Monel, Duplex & Hastelloy C	1" x 2" to 12" x 16"	-450°F to +500°F	15 psig to 6170 psig	UV	✓	✓	✓	✓	✓	✓	✓
3800 Series Snap Acting Pilot					UV	✓	✓	✓				

Portfolio of Pressure Relief Valves

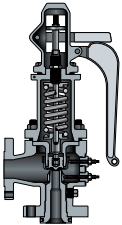
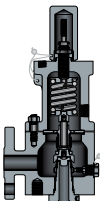
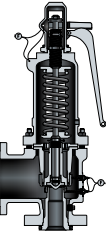
Valve	Material	Size Inches	Temperature Range	Pressure Range	ASME	Balanced or Bellows	Service				Nuclear	CE Stamped
							Air	Steam	Water	Multi		
 4200/4400 Series	Carbon Steel, Stainless Steel, Chrome-Moly	1-1/4" x 1-1/2" to 6" x 8"	-20°F to +1000°F	15 psig to 1000 psig	UV & V			✓				✓
 4700 Series	Stainless Steels, Carbon Steels	1/2" x 3/4" to 1" x 1-1/2"	-450°F to 1000°F	5 psig to 6000 psig	UV	✓	✓	✓			✓	
4700L Series					UV	✓		✓	✓	✓		
 6400/6600 Series	Carbon Steel, Stainless Steel, Chrome-Moly	1" x 2" to 4" x 6"	-20°F to +1000°F	15 psig to 1500 psig	UV & V		✓	✓				

Certifications and Approvals:

- ASME V, UV, NV and NPT
- National Board Approval, NB
- ISO 9001:2015
- PED 2014/68/EU (European Pressure Equipment Directive)
- ATEX 2014/34/EU (European Potentially Explosive Atmospheres)
- CSA Z299.2/3/4, B51, N285.0 (Canadian Registration)
- CRN (Canadian Registration Number)
- CSQL (China Safety Quality License)
- Customs Union Certificates TR CU 010/2001 and TR CU 023/2013
- US Coast Guard
- Nuclear - 10 CFR 50 Appendix B, NCA-4000, NQA-1, N285.0
- First Point Assessment Limited

Refer to individual product catalogs for product specific certification.





Warranty

All Farris Engineering Products have a Warranty Period of twelve months from first installation or eighteen months from delivery, whichever is sooner. All other warranty terms are as per Curtiss-Wright Industrial Standard Terms and Conditions, a copy which is available at www.cw-industrialgroup.com/About/Group-Policies/Terms-Conditions.aspx. or contact your local representative.

**CURTISS -
WRIGHT**



Farris Engineering, a Division of Curtiss-Wright

Headquarters: 10195 Brecksville Road, Brecksville, OH 44141 USA • Telephone: 440-838-7690 • Fax: 440-838-7699 • www.cw-valvegroup.com/farris

Offices Worldwide: For a listing of our global sales network, visit our website at www.cw-valvegroup.com/farrisdistributors.

While this information is presented in good faith and believed to be accurate, Farris Engineering, division of Curtiss-Wright Corporation, does not guarantee satisfactory results from reliance on such information. Nothing contained herein is to be construed as a warranty or guarantee, expressed or implied, regarding the performance, merchantability, fitness or any other matter with respect to the products, nor as a recommendation to use any product or process in conflict with any patent. Farris Engineering, division of Curtiss-Wright Corporation, reserves the right, without notice, to alter or improve the designs or specifications of the products described herein.